

RULLO SIGMA (FRIZIONE DOPPIA) SIGMA ROLLER (DUAL FRICTION)

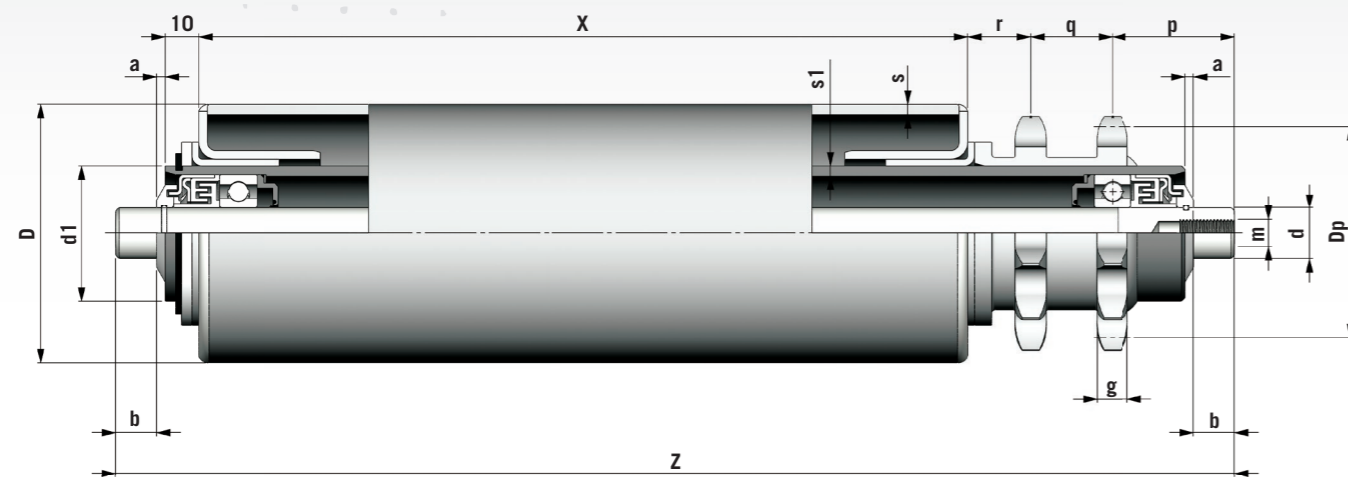

EXEC B2

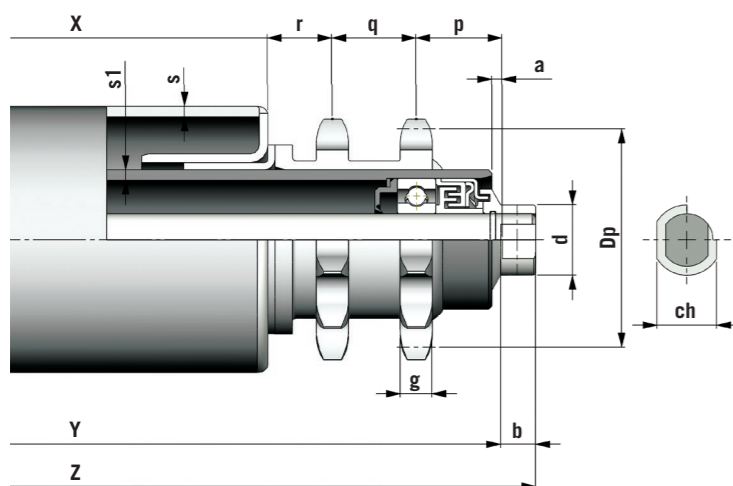

EXEC A

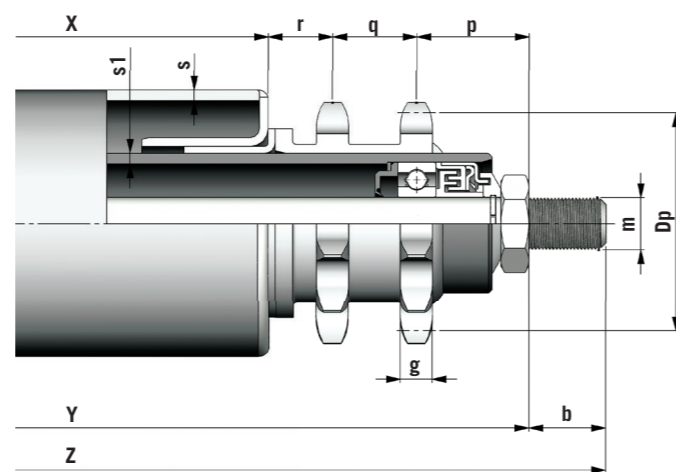

EXEC C

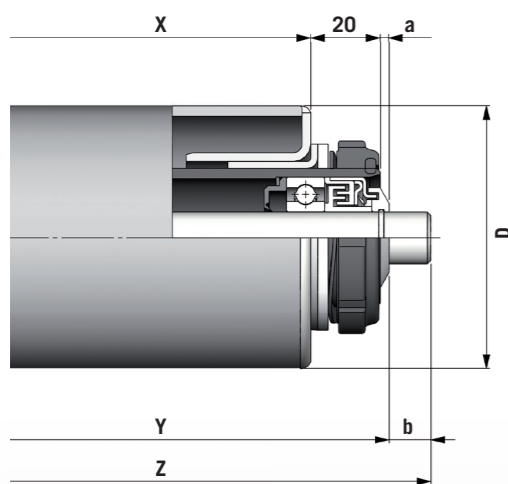

Frizione registrabile
Adjustable frictioned pinion sproket

RULLO SIGMA (FRIZIONE DOPPIA) SIGMA ROLLER (DUAL FRICTION)

TIPO TYPE	PASSO CATENA CHAIN PITCH	N° DENTI Z N. TEETH Z	Dp	ESEC. ASSE SHAFT CONFIG.	DIMENSIONI - DIMENSIONS												PESO (KG) WEIGHT (KG)			
					a	b	m	ch	p	q	r	g	D	d	d1	s	X=200	Al mm - Per mm		
60-40/15	1/2" x 5/16"	14	57.07	A	4	9		17	14.5		21	18.5	7	60	15	42	3	1.867	0.00560	
				B2	4	12	10x15	26.5												
				C	12	25	14	22.5												
76-40/15	1/2" x 5/16"	14	57.07	A	4	9		17	14.5		21	18.5	7	76	15	42	3	2.180	0.00679	
				B2	4	12	10x15	26.5												
				C	12	25	14	22.5												
89-40/15	1/2" x 5/16"	17	69.11	A	4	9		17	14.5		21	18.5	7	89	15	54	3	2.635	0.00775	
				B2	4	12	10x15	26.5												
				C	12	25	14	22.5												
102-40/15	5/8" x 3/8"	12	61.34	A	4	9		17	16.5		24	21.5	8.8	102	15	43	3	2.897	0.00871	
				B2	4	12	10x15	28.5												
				C	12	25	14	24.5												
108-40/15	5/8" x 3/8"	12	61.34	A	4	9		17	16.5		24	21.5	8.8	108	15	43	3.5	3.251	0.01040	
				B2	4	12	10x15	28.5												
				C	12	25	14	24.5												

MOTORIZZAZIONI DISPONIBILI AVAILABLE DRIVES

PASSO CATENA CHAIN PITCH	N° DENTI MINIMO Z MINIMUM N. TEETH Z	Ø PRIM. Ø PRIM.
1/2" x 5/16"	13	53.06
5/8" x 3/8"	12	61.34
3/4" x 7/16"	10	61.64

ESECUZIONI A RICHIESTA	AVAILABLE OPTIONS
Esecuzioni assi diverse	Other shaft configurations
Posizione corone diverse	Other gear positions
Tubo acciaio inox	Stainless steel tube
Asse acciaio inox	Stainless steel shafts
Zincatura a freddo	Cold galvanization
Carbonitrurazione	Carbonitriding
Rilsanizzazione	Rilsan coating
Rivestimento in gomma vulcanizzata	Vulcanized Rubber coating
Rivestimento con poliuretano	Polyurethane coating
Rivestimento con guaina in PVC	PVC Sheath coating
Rivestimento con guaina in gomma	Rubber sheath coating
Versione per catena tangenziale singola o doppia	Single or dual tangential chain version
Frizione registrabile	Adjustable frictioned pinion sproket